

1 Appearance

- ① Camera ② IR Supplement Light ③ Screen
- ④ Loudspeaker ⑤ Buttons ⑥ Microphone ⑦ Card Reading Area
- ⑧ Fingerprint Recognition Module ⑨ TAMPER

Note: The appearance of the device vary according to different model. Refers to the actual device.

2 Terminal

- LAN: Network Signal Input
- BTN1/BTN2: Exit Button Input
- 485A+/485A-: External RS-485 Card Reader
- 485B+/485B-: External Elevator Controller
- GND: Grounding
- COM1/COM2: Common Interface
- NC1/NC2: Door Lock Relay Output (Normally Close)
- NO1/NO2: Door Lock Relay Output (Normally Open)
- SEN1/SEN2: Door Contact Input
- DC 12 V: 12 VDC Power Input

Note:
 ● The reserved port is used for debugging only.
 ● Wiring description refers to the User Manual.

3 Installation

- Before you begin:
- Accessories that you need to prepare for installation: gang box.
 - Make sure the power supply meet the power requirements of the door station (12 VDC, 2 A).
 - Make sure all the related equipment is power-off during the installation.
 - Wire the cables before installation.

Accessory

- The dimension of the gang box is 364 mm (W) × 118 mm (H) × 40 mm (D).
- The installation hole should be larger than the actual size. The suggested dimension of the installation hole is 364.3 mm (W) × 118.6 mm (H) × 40.2 mm (D).

Flush Mounting

- Cave an installation hole on the wall. Pull the cable out from the wall.
- Note:
 The suggested dimension of the installation hole is 364.3 mm (W) × 118.6 mm (H) × 40.2 mm (D).
 The suggested length of the cables left outside is 250 mm.
- Install the gang box into the wall.
 - Remove the plastic sheet of the gang box with the tool.
 - Insert the gang box into the installation hole. Mark the gang box screw holes' position with a marker, and take out the gang box.
 - Drill 4 holes according to the marks on the wall, and insert the expansion sleeves into the screw holes.
 - Fix the gang box with 4 expansion bolts.
 - Fix the gap between the gang box and wall with concrete. Remove the mounting ears with tool after concrete is dry. Connect the cables according to the Wiring Description in User Manual.
 - Insert the door station into the gang box. Slide the door station down and fix it with 2 set screws. Apply Silicone sealant among the joints between the device and the wall (except the lower side) to keep the raindrop from entering.

4 Configuration

1 Activate Device

- You are required to activate the device first by setting a strong password for it before you can use the device.
- Power on the device to enter the activation page automatically.
 - Create a password and confirm it.
 - Press # to activate the door station.

- Note:
 ● Enter an 8 to 16 characters admin password.
 ● When entering the password, taking the numeric key 2 as example, press the numeric key 2 once, the text field shows "2", and press it again in 1.5 s, the text field shows "a", and press it again in 1.5 s, the text field shows "b", and so on.
 ● Hold 0 to enter special characters.
 ● Press # to confirm the password.
 ● Press * to delete the password during entering.

2 Call Resident

- The door station can work as main/sub door station, and outer door station, which correspond to different calling resident modes respectively.
- Call from Main/Sub Door Station
 Press number button to enter the calling page.
 Enter the room No. and press call button again to call.
- Call from Outer Door Station
 Press number button to enter the calling page.
 Enter Building No. + # + Unit No. + # + Room No. and press call button to call resident.

3 Call Center

- Press number button to enter the calling page.
 Press center button to call. Press * to cancel during calling management center.

4 Unlock Door

- The device support unlock the door by presenting card, entering password, and fingerprint. Here takes unlock by entering password and unlock by presenting card for example.
- Note: You should create the password and add the card to the device first.
- Unlock by Entering Password
 ● Common Password
 Press number button, enter # + room No. + password + # to unlock the door.
 ● Public Password
 Note: Create the public password via IVMS-4200 Client Software remotely first.
 Press number button, enter # + public password + # to unlock the door.
- Unlock by Presenting Card
 Present the card on the card reading area to unlock the door.

5 Appendix

1 Tips When Collecting/Comparing Face Picture

- Keep your expression naturally when collecting or comparing face pictures.
- Do not wear hat, sunglasses, or other accessories that can affect the facial recognition function.
- Do not make your hair cover your eyes, ears, etc. and heavy makeup is not allowed.
- In order to get a good quality and accurate face picture, position your face looking at the camera when collecting or comparing face pictures.
- Make sure your face is in the middle of the collecting window.
- The recommended distance when collecting/comparing face pictures is between 400 mm and 500 mm.

2 Tips When Importing Face Picture

- Picture format: JPG.
- Picture size cannot exceed 200 KB.
- A pure background color is required. White is the best.

Note: The door station can be configured via IVMS-4200 Client Software remotely.

★ Refer to Video Intercom Face Recognition Door Station User Manual (scan the QR code) for details.

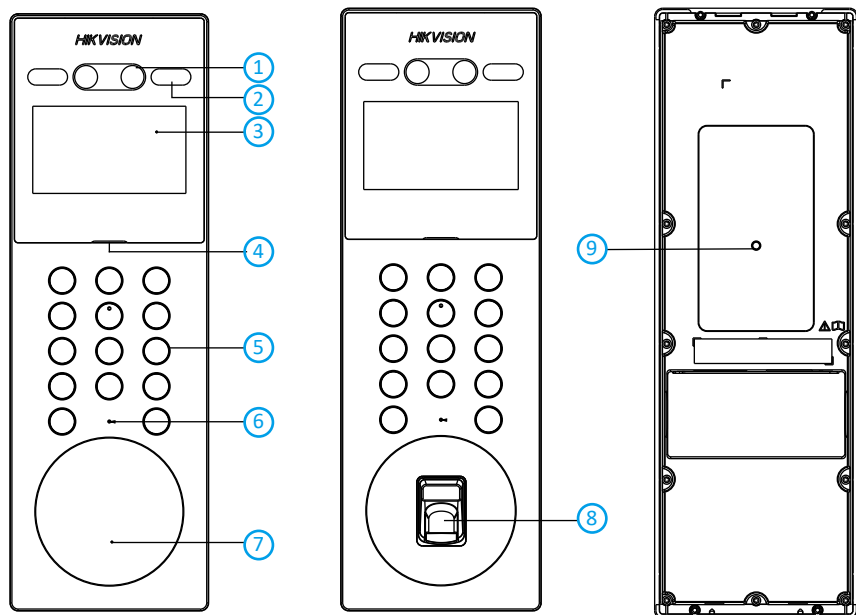

2

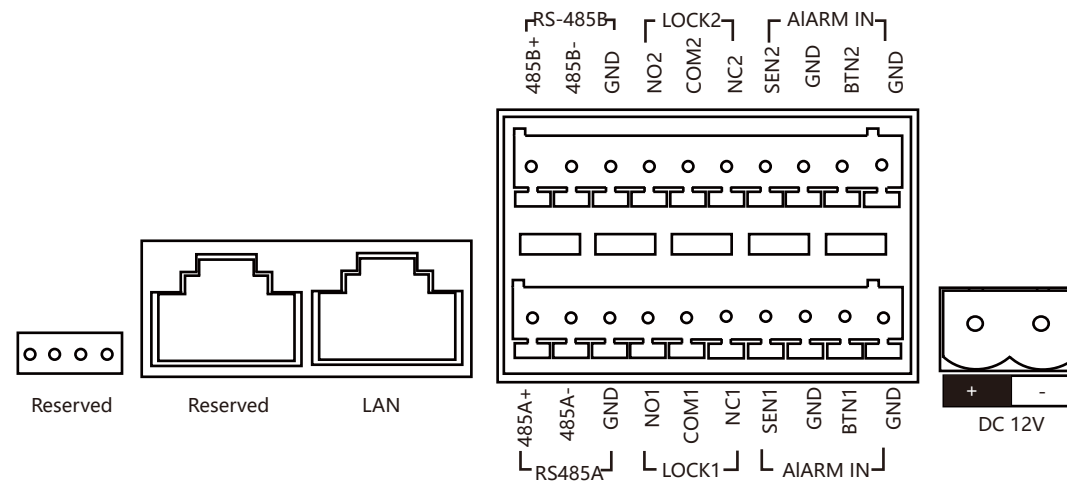

3

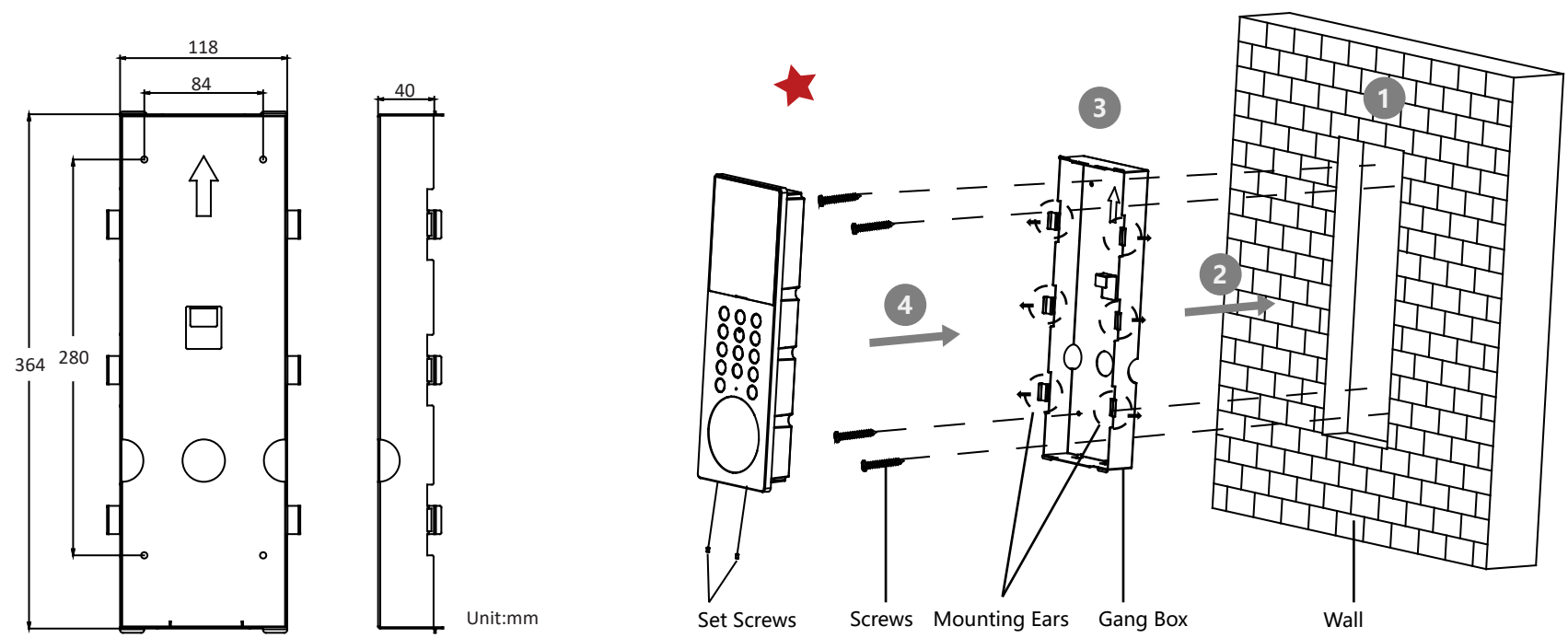

6

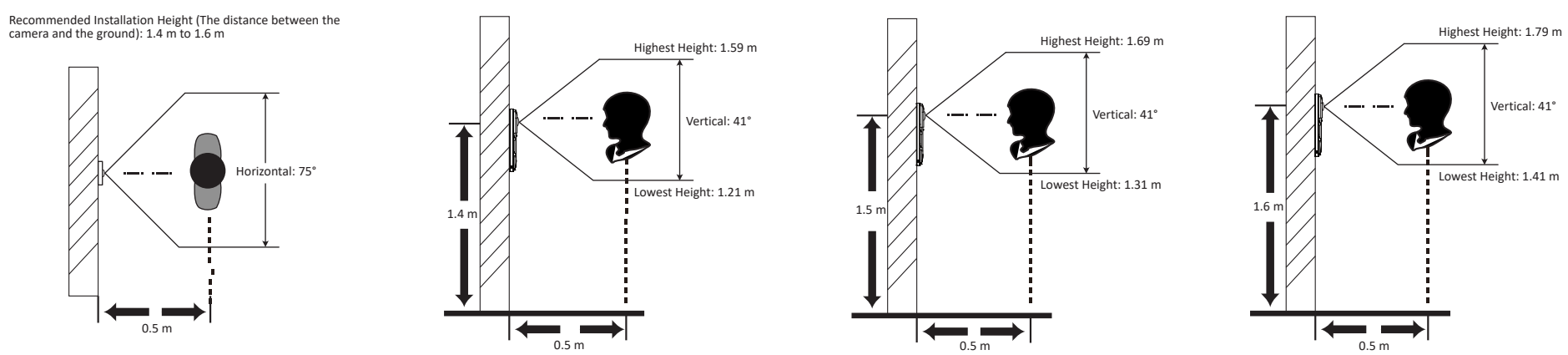

FRANÇAIS

Références du schéma

1 Apparence

Remarque : l'apparence de l'appareil varie selon le modèle. Reportez-vous à l'appareil proprement dit.

2 Borne

Remarque : pour la description des bornes et du câblage, reportez-vous à la figure et au manuel de l'utilisateur.

3 Installation

Avant de commencer :

- Assurez-vous que l'appareil dans l'emballage est en bon état et que toutes les pièces d'assemblage sont incluses.
- Assurez-vous que l'équipement connexe est bien hors tension pendant l'installation.
- Vérifiez les spécifications relatives à l'environnement d'installation du produit.

Remarque : pour l'installation, reportez-vous à la figure et au manuel de l'utilisateur pour plus de détails.

4 Premiers pas

1 Activer un appareil

Vous devez activer l'appareil en programmant tout d'abord un mot de passe fort avant de pouvoir l'utiliser. Activez l'appareil localement ou à distance via le logiciel client iVMS-4200.

2 Configuration à distance

Remarque : Pour plus de détails sur la configuration, consultez le manuel d'utilisation.

PORTUGUÊS

Referências do diagrama

1 Aspeto

Nota: O aspeto do dispositivo varia consoante o modelo. Consulte o próprio dispositivo.

2 Terminal

Nota: Para as descrições de cablagem e dos terminais, consulte a figura e o manual do utilizador.

3 Instalação

Antes de começar:

- Certifique-se de que o dispositivo na embalagem se encontra em boas condições e de que todas as peças de montagem estão incluídas.
- Certifique-se de que, durante a instalação, todo o equipamento relacionado se encontra desligado.
- Verifique a especificação do produto para o ambiente de instalação.

Nota: Para a instalação, consulte a figura e o manual do utilizador para ver detalhes.

4 Introdução

1 Ativar dispositivo

Em primeiro lugar, tem de ativar o dispositivo definindo uma palavra-passe segura para o mesmo antes de utilizar o dispositivo.

Ative localmente o dispositivo ou remotamente através do software de cliente iVMS-4200 iVMS-4200.

2 Configuração remota

Nota: Para obter informações sobre a configuração remota, consulte o Manual do Utilizador.

DEUTSCH

Verweise auf Schaubilder

1 Aufbau

Hinweis: Der Aufbau des Geräts variiert je nach Modell. Beziehen Sie sich auf das tatsächliche Gerät.

2 Anschlussklemmen

Hinweis: Beschreibungen der Anschlussklemmen und der Verdrahtung finden Sie in der Abbildung und im Benutzerhandbuch.

3 Montage

Bevor Sie beginnen:

- Achten Sie darauf, dass sich das Gerät in der Verpackung in gutem Zustand befindet und alle Montageteile enthalten sind.
- Achten Sie darauf, dass die Geräte während der Montage ausgeschaltet sind.
- Überprüfen Sie die Produktspezifikation für die Installationsumgebung.

Hinweis: Einzelheiten zur Installation finden Sie in der Abbildung und im Benutzerhandbuch.

4 Erste Schritte

1 Gerät aktivieren

Sie müssen das Gerät vor der Verwendung zuerst aktivieren. Legen Sie dazu ein starkes Passwort fest. Aktivieren Sie das Gerät lokal oder aus der Ferne über die iVMS-4200-Clientsoftware.

2 Fernkonfiguration

Hinweis: Weitere Informationen zur Konfiguration finden Sie im Benutzerhandbuch.

ESPAÑOL

Referencias del diagrama

1 Apariencia

Nota: el aspecto del dispositivo varía en función del modelo. Remítase al dispositivo en cuestión.

2 Terminal

Nota: para las descripciones de los terminales y del cableado, consulte la figura y el manual de usuario.

3 Instalación

Antes de empezar:

- Asegúrese de que el dispositivo del paquete esté en buenas condiciones y que todas las piezas de montaje estén incluidas.
- Asegúrese de que el equipo relacionado esté apagado durante la instalación.
- Compruebe las especificaciones de producto para el entorno de instalación.

Nota: si durante la instalación necesita más información, consulte la figura y el manual de usuario.

4 Primeros pasos

1 Activar dispositivo

Debe activar primero el dispositivo estableciendo una contraseña segura antes de usarlo. Active el dispositivo de forma local o a distancia mediante el software de cliente iVMS-4200.

2 Configuración remota

Nota: consulte el manual de usuario para ver la configuración.

ČEŠTINA

Popis obrázků

1 Vzhled

Poznámka: Vzhled zařízení se u různých modelů liší. Viz konkrétní zařízení.

2 Svorkovnice

Poznámka: Popis svorky a zapojení naleznete na obrázku a v návodu k použití.

3 Montáž

Drive než začnete:

- Ujistěte se, zda je zařízení v balení v dobrém stavu a zda jsou přítomny všechny dodávané součásti.
- Během instalace se ujistěte, že všechna související zařízení jsou vypnutá.
- Zkontrolujte technické údaje výrobku podle instalačního prostředí.

Poznámka: Podrobnosti týkající se postupu instalace naleznete na obrázku nebo v návodu k použití.

4 Začínáme

1 Aktivace zařízení

Před použitím zařízení je nejprve nutné provést jeho aktivaci nastavením silného hesla. Zařízení aktivujte v místě nebo vzdáleně prostřednictvím klientského softwaru iVMS-4200.

2 Vzdálená konfigurace

Poznámka: Konfiguraci naleznete v uživatelské příručce.

ITALIANO

Riferimento schemi

1 Aspetto

Nota: l'aspetto del dispositivo varia in base al modello. Fare riferimento al dispositivo effettivo.

2 Morsettiere

Nota: per la descrizione del cablaggio e dei terminali, consultare la figura e il manuale d'uso.

3 Installazione

Prima di iniziare:

- Assicurarsi che il dispositivo e l'imballaggio siano in buone condizioni e che siano presenti tutte le parti necessarie per l'assemblaggio.
- Verificare che durante l'installazione tutte le apparecchiature correlate siano spente.
- Controllare che le specifiche del prodotto siano compatibili con l'ambiente di installazione.

Nota: per ulteriori informazioni sull'installazione, consultare la figura e il manuale d'uso.

4 Operazioni preliminari

1 Attiva dispositivo

Per potere utilizzare il dispositivo, occorre per prima cosa attivarlo impostando una password sicura.

Attivare il dispositivo localmente o da remoto tramite il software client iVMS-4200.

2 Configurazione remota

Nota: Per la configurazione, consultare il Manuale dell'utente.

DANSK

Diagramoversigt

1 Beskrivelse

Bemærk: Enhedens udseende kan variere afhængigt af model. Der henvises til den faktiske enhed.

2 Terminal

Bemærk: Find beskrivelse af terminaler og ledningsføring i figuren og brugervejledningen.

3 Installation

Før du starter:

- Kontrollér, at enheden i pakken er i god tilstand, og at alle dele til samling medfølger.
- Kontrollér, at alt tilknyttet udstyr er slukket under installationen.
- Kontrollér produktspecifikationerne for installationsmiljøet.

Bemærk: Find oplysninger om installation i figuren og brugervejledningen.

4 Kom godt i gang

1 Aktivér enhed

Du skal først aktivere enheden ved at indstille en stærk adgangskode, før du kan anvende enheden.

Aktivér enheden lokalt eller via fjernadgang via iVMS-4200-klientsoftware.

2 Fjernbetjent konfiguration

Bemærk: Find oplysninger om konfiguration i brugervejledningen.

